

# An All-Digital Polar PWM Transmitter

Muhammad Touqir Pasha<sup>a</sup>, Muhammad Fahim Ul Haque<sup>a,b</sup>, Jahanzab Ahmad<sup>c</sup>, Ted Johansson<sup>a</sup>

<sup>a</sup> Linköping University, Linköping, Sweden

<sup>b</sup> NED University of Engineering and Technology, Karachi, Pakistan

<sup>c</sup> Intel Corporation, High Wycombe, United Kingdom

# Outline

- Introduction
  - Transmitters for high data rate communication and high efficiency
  - Transmitter architectures using SMPAs
- The All-Digital Modified Polar PWM Transmitter
  - Principle
  - FPGA implementation
- Results
  - Simulations
  - Measurements
- Summary and conclusions

# Introduction

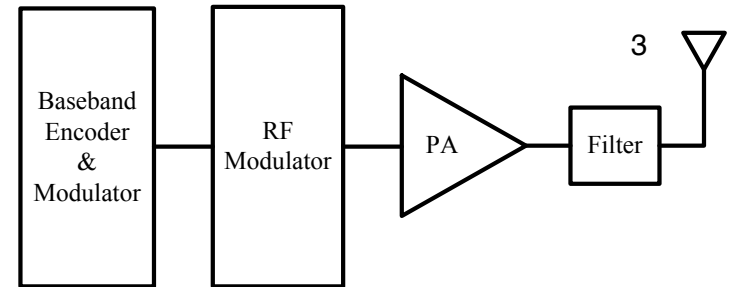

- Modern wireless data communication requires flexible transmitter architectures for multi-rate, multi-band signals.
- Possible to implement both baseband and RF using digital CMOS circuits.
- For R&D and small-volume products, this may be in the form of high-performance Field Programmable Gate Arrays, FPGAs.
- Modulation techniques, such M-QAM and OFDM, generate signals with non-constant amplitudes of wide range.
- To improve transmitter high efficiency, switch-mode PAs (SMPAs) has gained popularity, but use constant amplitude (on/off).
- We need special transmitter architectures to include the amplitude information.

# WLAN 802.11ac

Modulation and coding schemes

MCS Index <sup>[a]</sup>	Spatial Streams	Modulation type	Coding rate	Data rate (in Mbit/s) <sup>[7][b]</sup>							
				20 MHz channels		40 MHz channels		80 MHz channels		160 MHz channels	
				800 ns GI	400 ns GI	800 ns GI	400 ns GI	800 ns GI	400 ns GI	800 ns GI	400 ns GI
0	1	BPSK	1/2	6.5	7.2	13.5	15	29.3	32.5	58.5	65
1	1	QPSK	1/2	13	14.4	27	30	58.5	65	117	130
2	1	QPSK	3/4	19.5	21.7	40.5	45	87.8	97.5	175.5	195
3	1	16-QAM	1/2	26	28.9	54	60	117	130	234	260
4	1	16-QAM	3/4	39	43.3	81	90	175.5	195	351	390
5	1	64-QAM	2/3	52	57.8	108	120	234	260	468	520
6	1	64-QAM	3/4	58.5	65	121.5	135	263.3	292.5	526.5	585
7	1	64-QAM	5/6	65	72.2	135	150	292.5	325	585	650
8	1	256-QAM	3/4	78	86.7	162	180	351	390	702	780
9	1	256-QAM	5/6	N/A	N/A	180	200	390	433.3	780	866.7

# Introduction

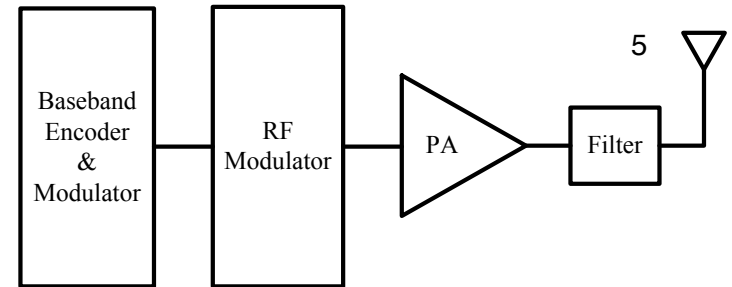

- Modern wireless data communication requires flexible transmitter architectures for multi-rate, multi-band signals.
- Possible to implement both baseband and RF using digital CMOS circuits.
- For R&D and small-volume products, this may be in the form of high-performance Field Programmable Gate Arrays, FPGAs.
- Modulation techniques, such M-QAM and OFDM, generate signals with non-constant amplitudes of wide range.
- To improve transmitter high efficiency, switch-mode PAs (SMPAs) has gained popularity, but use constant amplitude (on/off).
- We need special transmitter architectures to include the amplitude information.

# Introduction

- Outphasing: two constant-envelope signals with varying phase difference.

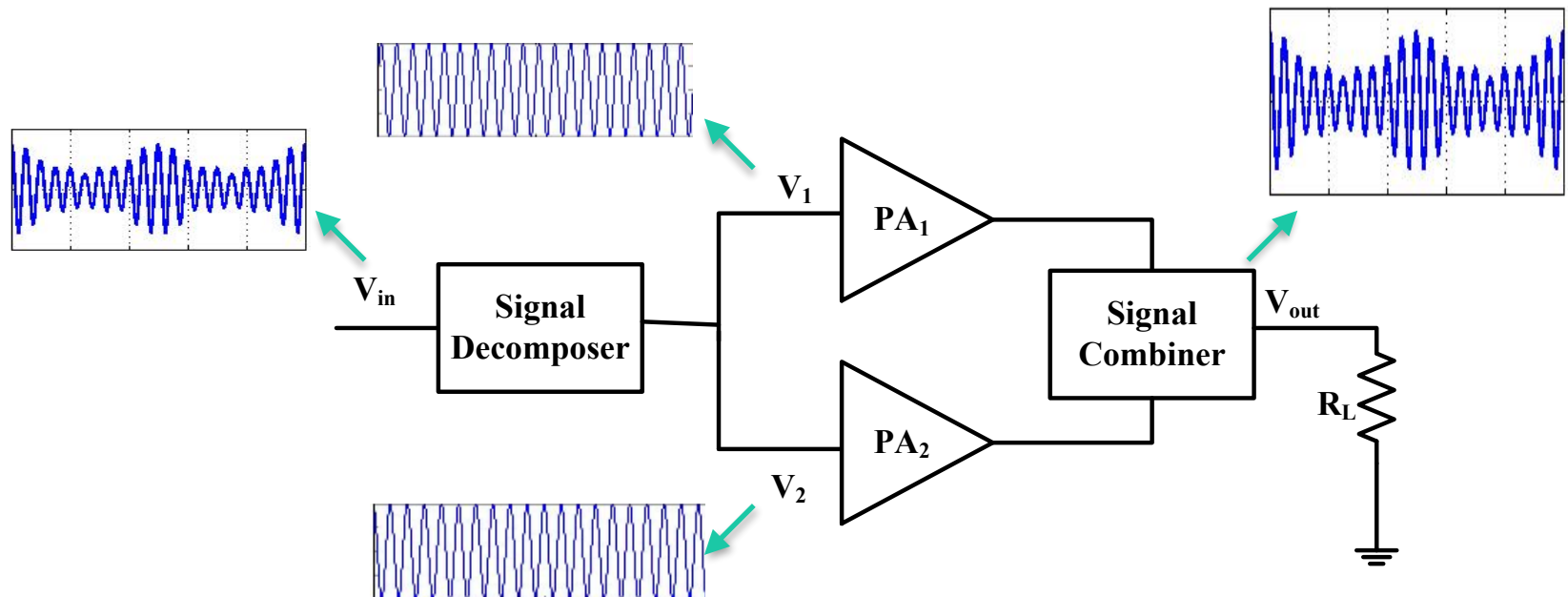

- Issues: Amplification paths mismatch, combiner implementation.

# Introduction

- RF-PWM: pulse-train with varying duty cycle at RF.

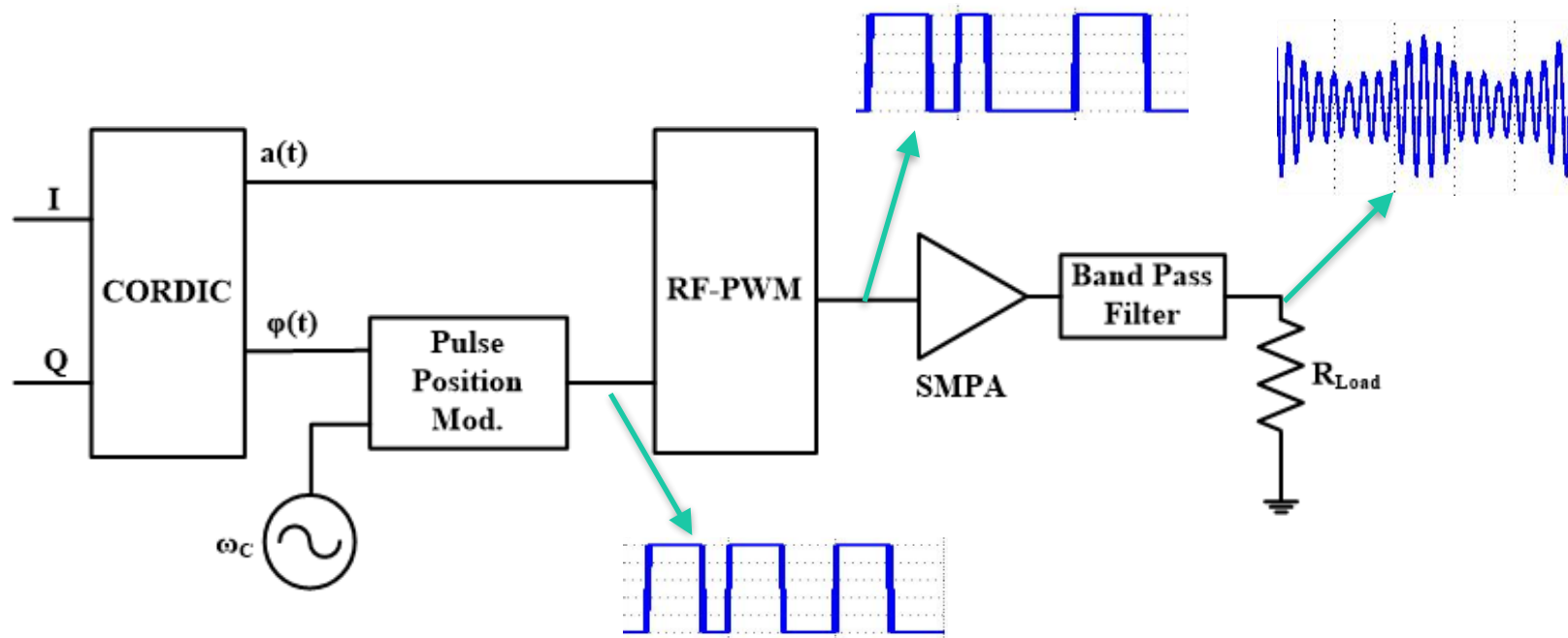

- Issues: Small dynamic range at high carrier frequency.

# Introduction

- Polar PWM: amplitude PWM at IF, phase-shifted carrier

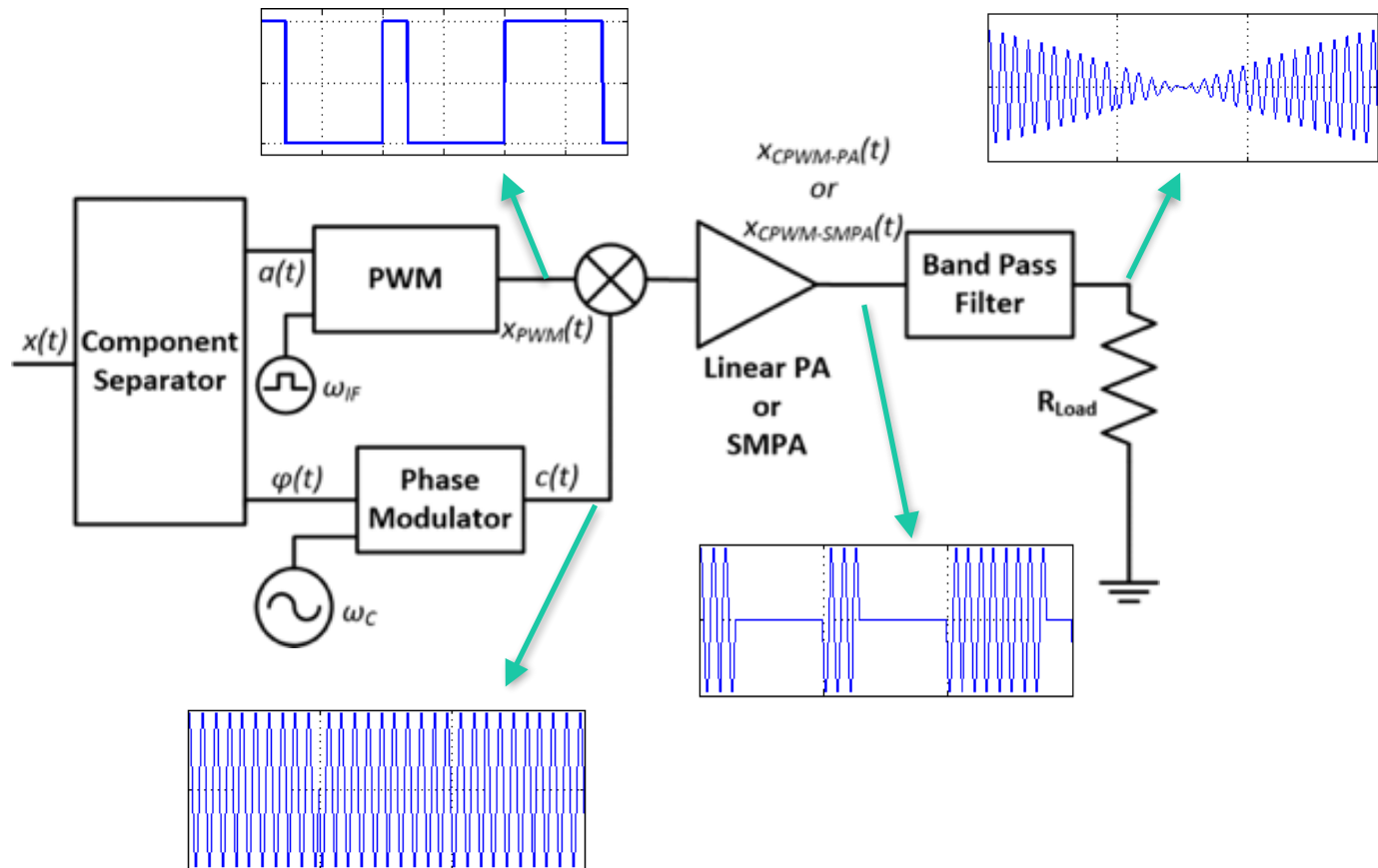



# Introduction

- Polar PWM issues: image distortion

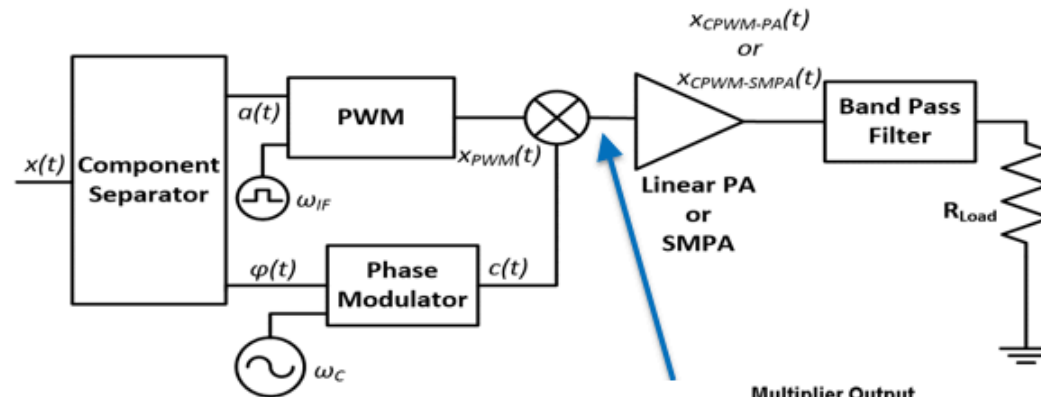
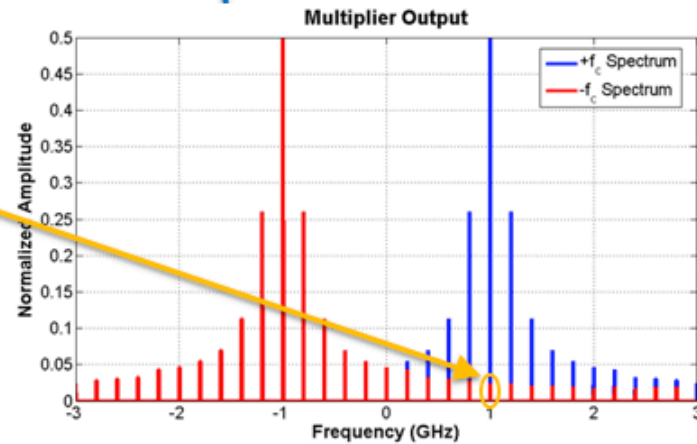
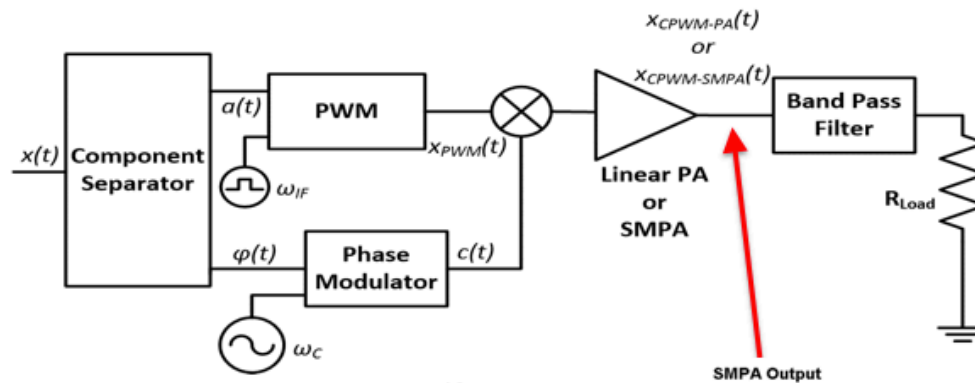

Image distortion



# Introduction

- Polar PWM issues: image distortion enhanced by non-linear SMPA



Switch-mode PA

Increased image distortion

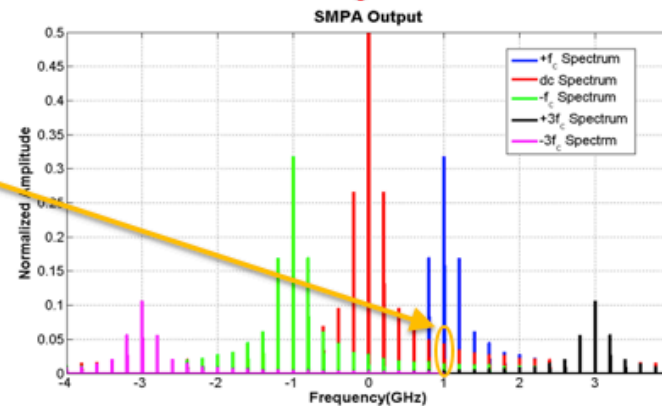

# An All-Digital Polar PWM Transmitter

- "Modified Digital PWM" (MD-PWM)
- Combines digital PWM and outphasing
  - Increased efficiency (SMPAs)
  - Outphasing eliminates image and alias distortion => improved ACLR and EVM compared to a D-PWMT.

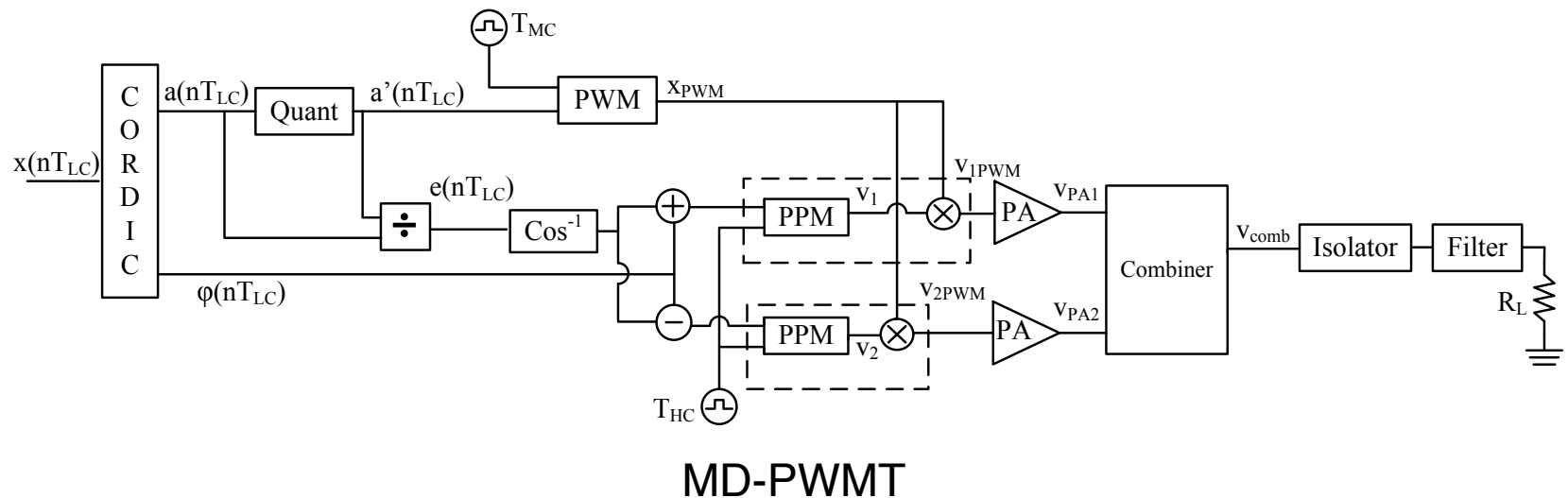

# A Modified All-Digital Polar PWM Transmitter

Muhammad Touqir Pasha, *Student Member, IEEE*, Muhammad Fahim Ul Haque, *Student Member, IEEE*, Jahanzeb Ahmad, and Ted Johansson, *Senior Member, IEEE*

**Abstract**—This paper presents an all-digital polar pulsewidth modulated (PWM) transmitter for wireless communications. The transmitter combines baseband PWM and outphasing to compensate for the amplitude error in the transmitted signal due to aliasing and image distortion. The PWM is implemented in a field programmable gate array (FPGA) core. The outphasing is implemented as pulse-position modulation using the FPGA transceivers, which drive two switch-mode power amplifiers fabricated in 130-nm standard CMOS. The transmitter has an all-digital implementation that offers the flexibility to adapt it to multi-standard and multi-band signals. As the proposed transmitter compensates for aliasing and image distortion, an improvement in the linearity and spectral performance is observed as compared with a digital-PWM transmitter. For a 20-MHz LTE uplink signal, the measurement results show an improvement of up to 6.9 dBc in the adjacent channel leakage ratio.

**Index Terms**—Software-defined radio (SDR), CMOS, FPGA, switch-mode PA (SMPA), outphasing, polar pulse-width modulation (P-PWM), aliasing distortion, image distortion, LTE.

## I. INTRODUCTION

SOFTWARE defined radios (SDRs) [1] supporting multiple communication standards are in high demand. A key aspect of SDRs is their ability to use the same hardware for the transmission of multi-band, multi-rate signals. In SDRs, the complete signal path from the baseband to the RF stage is usually implemented using digital circuits, which is made possible by the advances in the area of digital communication and CMOS fabrication. Field programmable gate arrays (FPGAs) in modern CMOS processes offer signal processing using embedded processors, gigabit I/Os and large embedded memories, making them suitable for implementing the high speed data processing for SDRs in the digital domain.

A typical transmitter block diagram for an SDR is shown in Fig. 1. The power amplifier (PA) usually consumes most of the power budget of a transmitter. Typically, linear PAs have been preferred for use in transmitters due to their superior

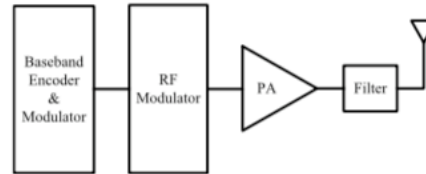

Fig. 1. SDR transmitter block diagram.

linearity but they have poor efficiency. In recent years, the use of switch-mode PAs (SMPAs) has gained popularity due to high efficiency and easier implementation in sub-micron CMOS [2].

Modern communication standards, such as WCDMA, LTE and WLAN, use modulation techniques like M-QAM and OFDM in order to improve bandwidth utilization. However, the resulting signals have a non-constant envelope, which cannot be directly amplified by an SMPA. Encoding schemes like outphasing [3]–[8], RF pulse-width modulation (RF-PWM) [9]–[13], and polar PWM (P-PWM) [14]–[20] can be used to convert the non-constant envelope signals into a binary form for highly efficient transmission using SMPAs.

In outphasing, the modulated envelope-varying signal is decomposed into two constant-envelope signals with the envelope information encoded in the phase difference of the two generated signals. These signals are combined after power amplification to generate the transmitted signal. Outphasing transmitters exhibit an improved spectral performance. However, the efficiency is strongly influenced by the type of combiner and the used PA [21], [22].

RF-PWM encodes the amplitude information of the transmitted signal by generating a pulse train with varied duty cycle at the carrier frequency. Such a transmitter is simple to implement and free from path-delay mismatches. However, the dynamic range of the output signal is limited by the maximum switching frequency of the PA [9], [10]. In [23] RF-PWM and outphasing are combined to improve the dynamic range of the transmitter. However, at higher carrier frequencies, the efficiency of such an implementation is reduced due to the limited resolution of the RF-PWM.

In polar PWM transmitters (P-PWMT), the amplitude information of the baseband signal is encoded into a PWM signal, and the phase information into the phase shift of the modulated carrier. The two signals are multiplied, amplified and filtered to generate an envelope-varying signal. P-PWMTs can use SMPAs, as the output signal has two levels. It has larger dynamic range compared to RF-PWM as it does

M. T. Pasha, M. F. U. Haque,  
J. Ahmad, T. Johansson

## A Modified All-Digital Polar PWM Transmitter

IEEE Transactions on  
Circuits and Systems-I, Vol.  
65, Issue 2, pp. 758-768,  
2018.

Manuscript received March 18, 2017; revised June 5, 2017; accepted June 27, 2017. Date of publication July 28, 2017; date of current version January 25, 2018. This paper was recommended by Associate Editor C. Li. (Corresponding author: Muhammad Touqir Pasha.)

M. T. Pasha and T. Johansson are with the Division of Integrated Circuits and Systems, Department of Electrical Engineering, Linköping University, SE 581 83 Linköping, Sweden (e-mail: muhammad.touqir.pasha@liu.se; ted.johansson@liu.se).

M. F. U. Haque was with the Division of Computer Engineering, Department of Electrical Engineering, Linköping University, SE 581 83 Linköping, Sweden. He is now with the Department of Electronic Engineering, NED University of Engineering and Technology, Karachi PK 752 70, Pakistan (e-mail: m.fahim@neduet.edu.pk).

J. Ahmad is with Intel Corporation, High Wycombe HP12 4XF, U.K. (e-mail: jahanzeb.ahmad@intel.com).

Color versions of one or more of the figures in this paper are available online at <http://ieeexplore.ieee.org>.

Digital Object Identifier 10.1109/TCSI.2017.2725980

1549-8328 © 2017 IEEE. Personal use is permitted, but republication/redistribution requires IEEE permission.

See [http://www.ieee.org/publications\\_standards/publications/rights/index.html](http://www.ieee.org/publications_standards/publications/rights/index.html) for more information.

# An All-Digital Polar PWM Transmitter

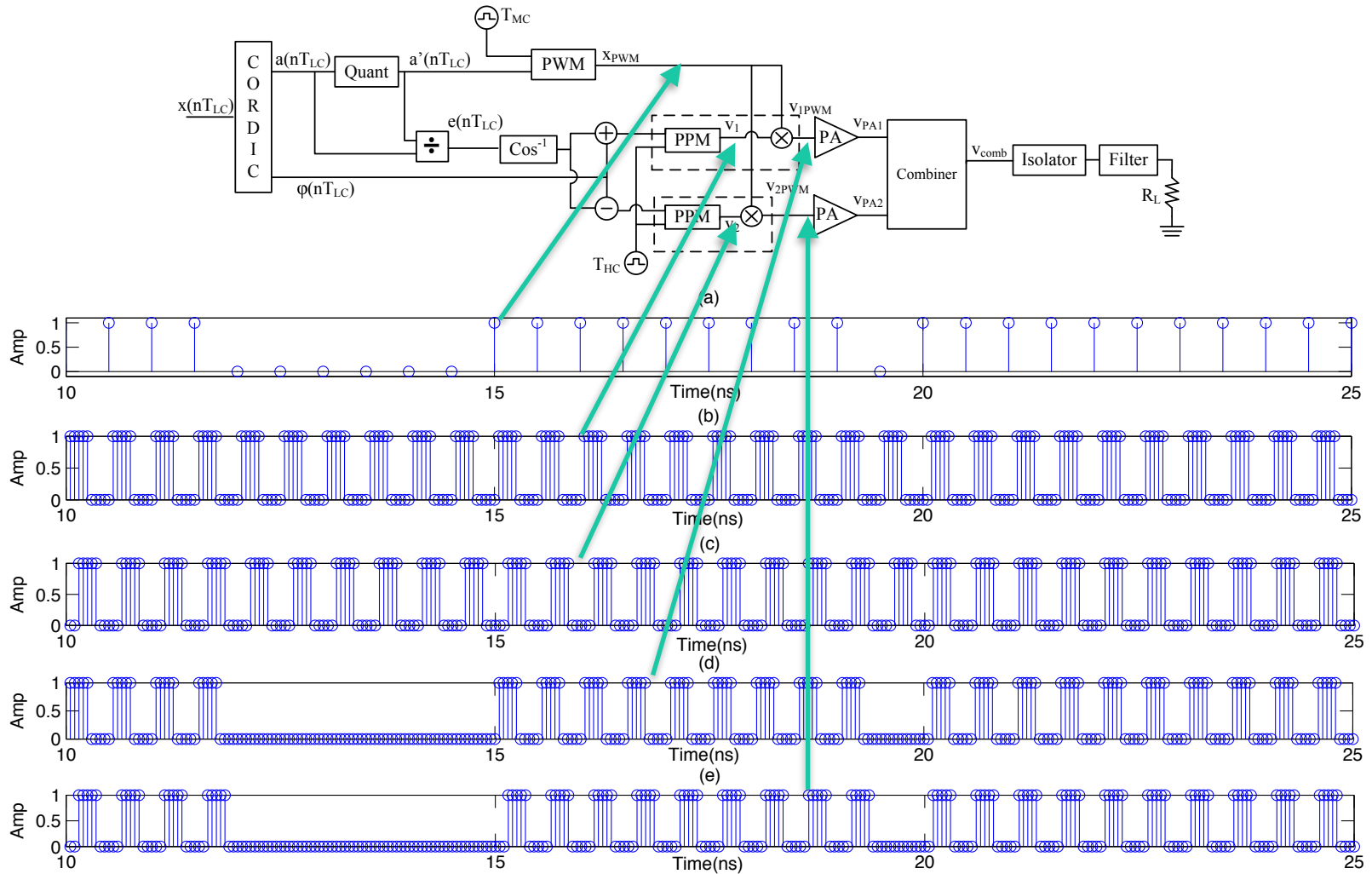

# An All-Digital Polar PWM Transmitter

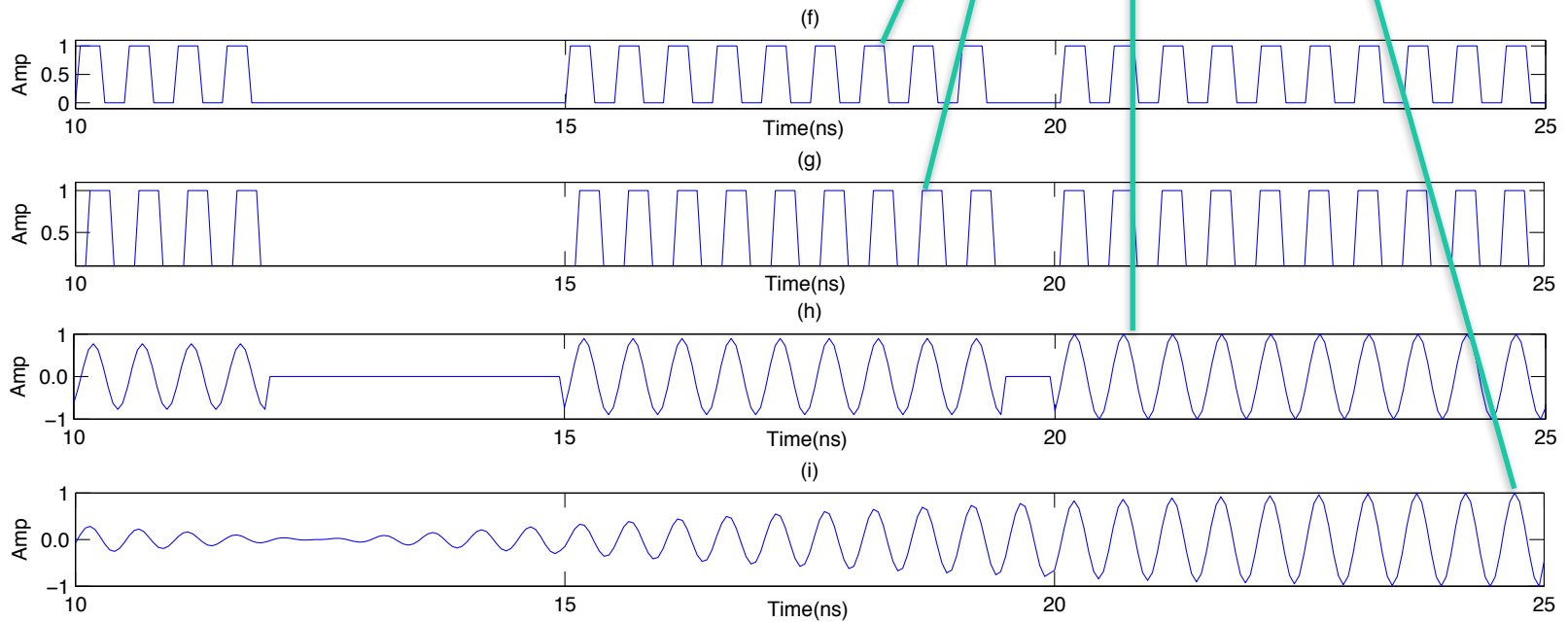
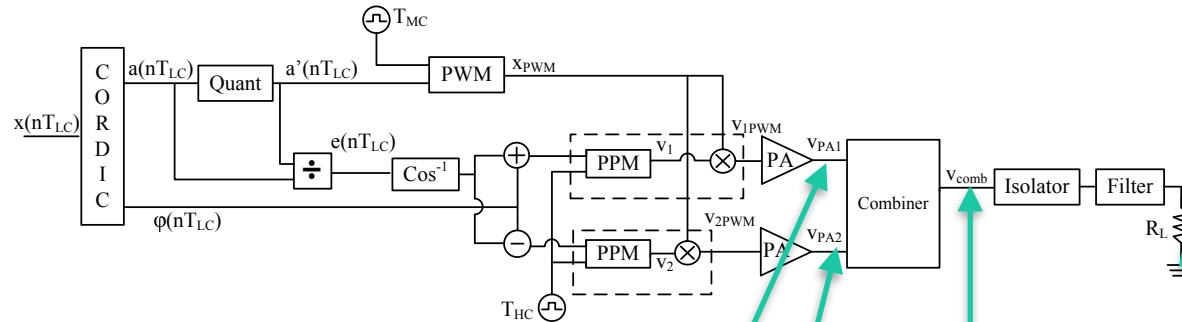

# FPGA implementation

- Intel/Altera Stratix IV GT FPGA with integrated 11.3 Gbps TRXs.
- PWM + high speed multipliers: FPGA core logic.
- PPM: FPGA core logic + TRX.

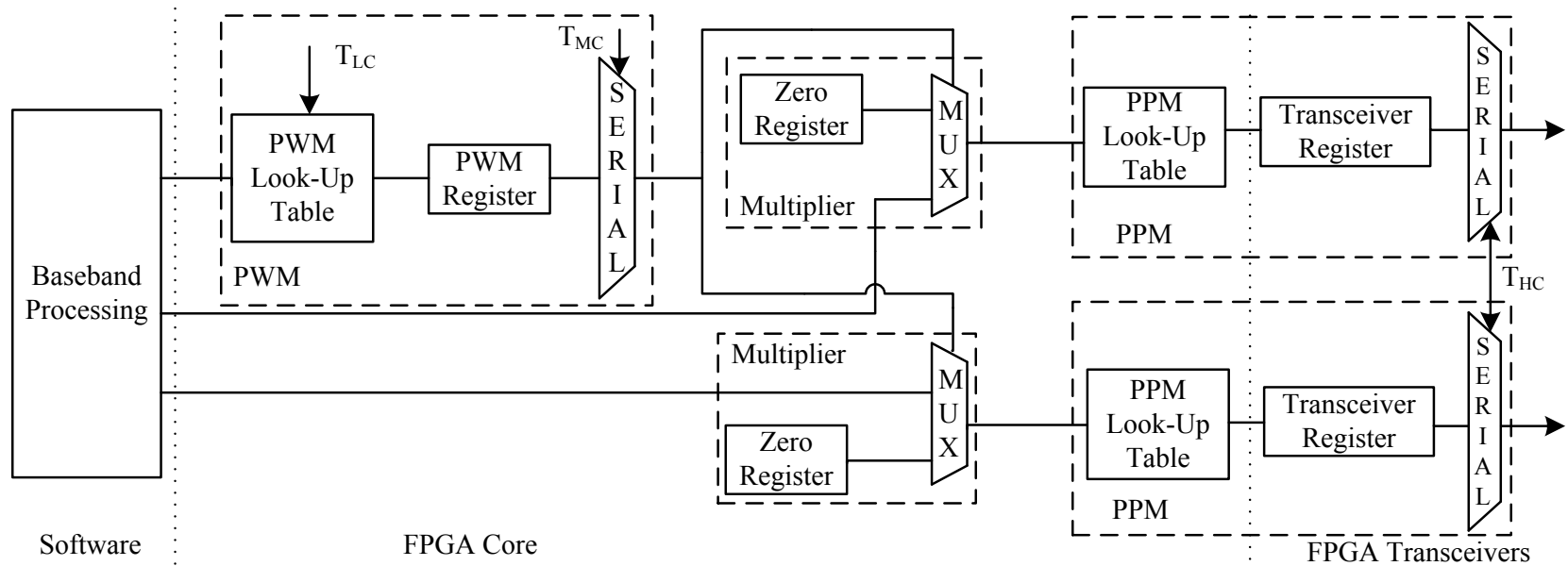

# Simulation results

- Circuit simulations using Cadence SpectreRF and Keysight ADS, 130 nm PDK.
- LTE 20 MHz uplink signal, PWM freq = 64 MHz, different phase resolutions.

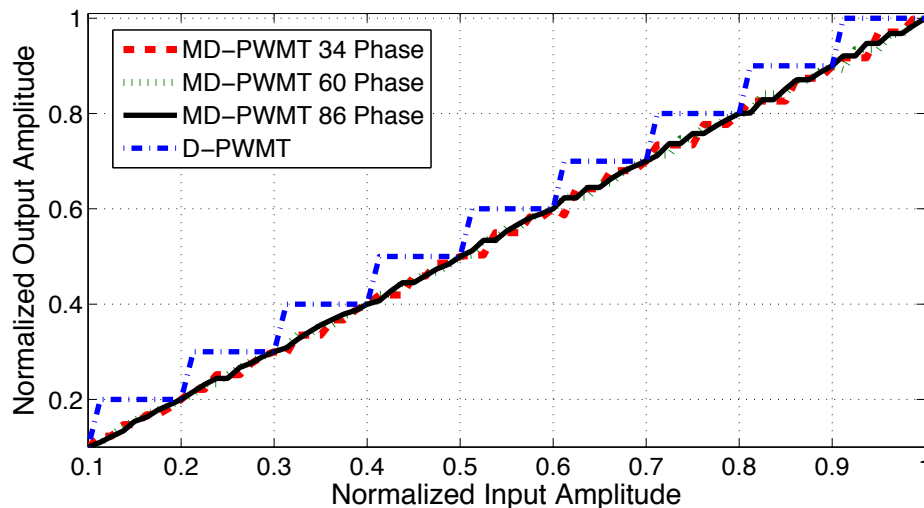

Amplitude linearity AM-AM

Number of phases	EVM		ACLR	
	D-PWMT	MD-PWMT	D-PWMT	MD-PWMT
<b>17</b>	18.20 %	6.26 %	24.6 dBc	31.6 dBc
<b>34</b>	7.38 %	3.17 %	27.0 dBc	36.1 dBc
<b>60</b>	6.87 %	1.89 %	27.3 dBc	38.0 dBc
<b>86</b>	6.68 %	1.33 %	27.4 dBc	39.0 dBc

EVM and ACLR



# Measurement results

- LTE 20 MHz uplink signal

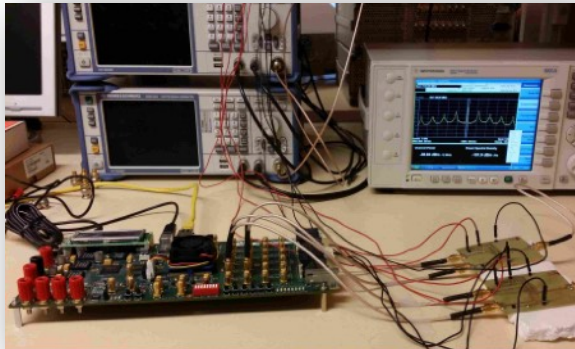
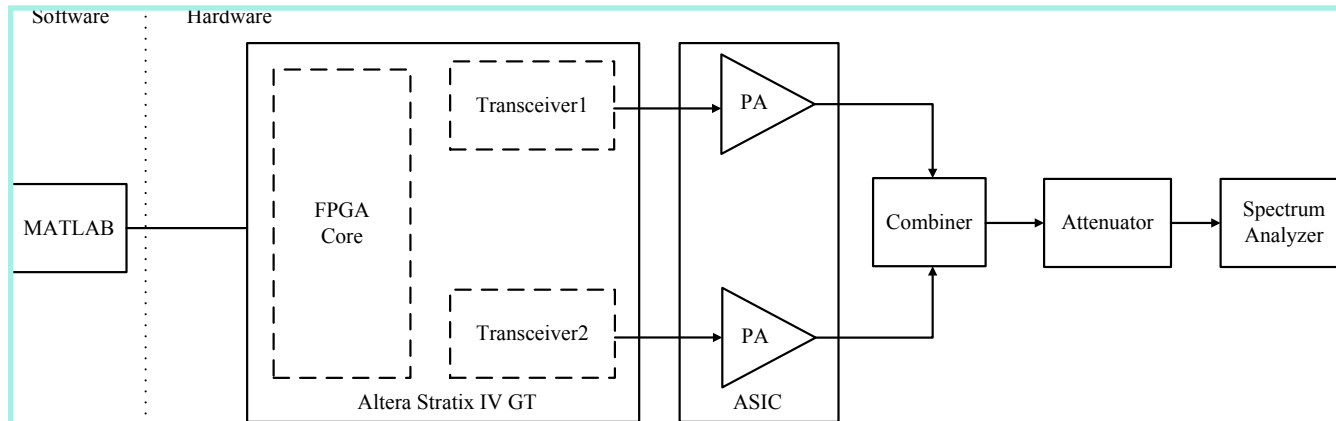

Measurement setup: FPGA, PAs

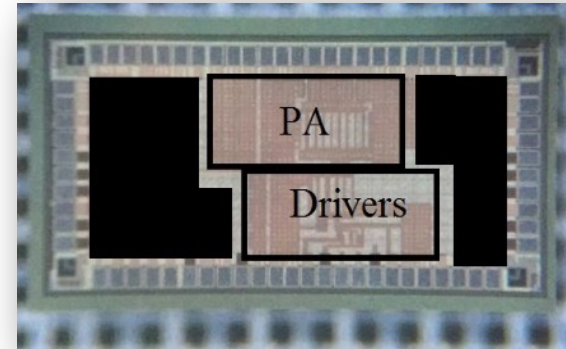

130 nm class-D PAs, area 0.6 mm<sup>2</sup>

# Measurement results

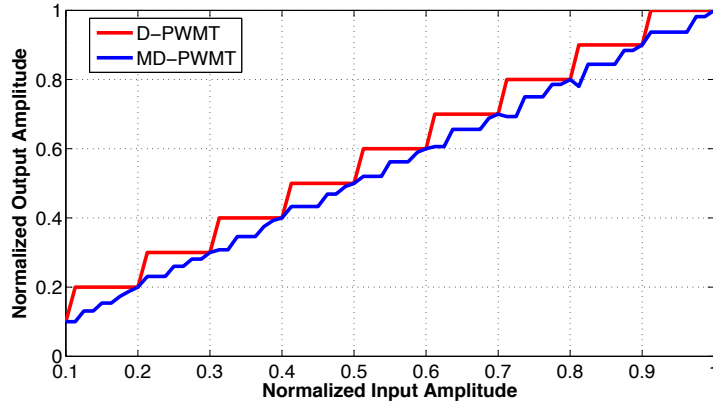

AM-AM linearity

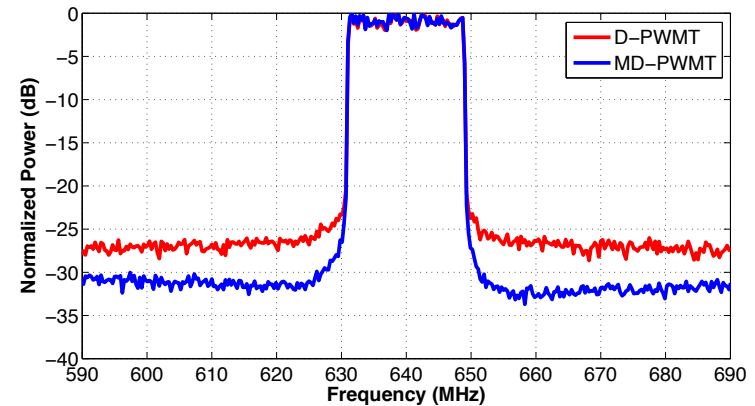

Output spectra,  $f_c = 640$  MHz

	$f_C^1$	$f_{IF}^2$	$f_{HC}^3$	ACLR	EVM	Average Efficiency	PA Peak Power
<b>D-PWMT</b>	320 MHz	64 MHz	10.88 GHz	26.9 dB	8.0 %	18.3 %	28.9 dBm
<b>MD-PWMT</b>	320 MHz	64 MHz	10.88 GHz	33.8 dB	4.4 %	17.0 %	28.9 dBm
<b>D-PWMT</b>	640 MHz	64 MHz	10.88 GHz	24.2 dB	19.1 %	15.5 %	27.8 dBm
<b>MD-PWMT</b>	640 MHz	64 MHz	10.88 GHz	30.5 dB	8.2 %	13.4 %	27.8 dBm

<sup>1</sup>  $f_C = \omega_C / 2\pi$ , carrier frequency

<sup>2</sup>  $f_{IF} = \omega_{IF} / 2\pi$ , pulse repetition frequency of the PWM signal

<sup>3</sup>  $f_{HC} = 1/T_{HC}$ , high clock frequency

# Summary and conclusions

- **All-digital PWM** with improved dynamic range, combining PWM, outphasing, and switch-mode PAs, has been presented.
- Amplitude: digital PWM.
- Phase: digital PPM of carrier frequency + quant error.
- Two PAs => needs combiner (space, losses).
- Measurement results, 20 MHz LTE uplink:
  - 6.3 dBc improved ACLR compared to D-PWM.
  - No aliasing or image distortion => improved EVM.
  - Somewhat reduced efficiency (1-2 %, combiner)

Thanks for your attention!  
Questions?

[www.liu.se](http://www.liu.se)